

## AXIAL FANS



# BB

## AC AXIAL FANS

Provides a strong air circulation in silence with the ideal vane angels.  
Can be mounted easily to windows and walls.

### Technical Drawings

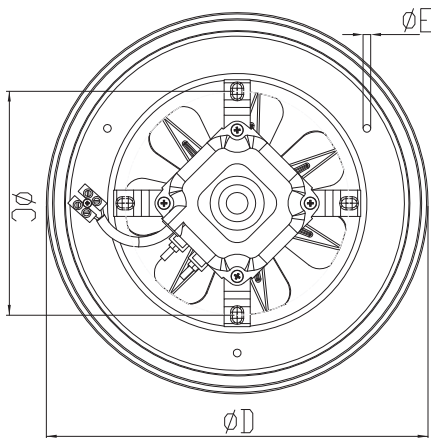
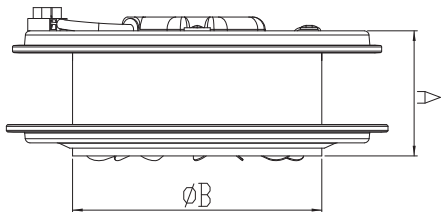

#### MATERIAL

: The housing is made of electrostatic powder coated sheet steel, impeller is made of aluminum.

#### INSULATION CLASS

: Class B

#### DIRECTIVE

: EN 60335-1, EN 60335-2-80

#### SPEED CONTROL

: Speed can be adjusted using an optional controller.

#### APPLICATION AREAS

: Kitchens, bathrooms, offices, etc. for taking polluted air, smoke and undesired smells out.

### Accessories



### BSC

TYPE	A	B	C	D	E
BB 160	80	162	148	236	5
BB 200	102	202	178	282	5
BB 250	102	248	234	332	5
BB 300	102	298	284	380	5

Dimensions are in (mm)

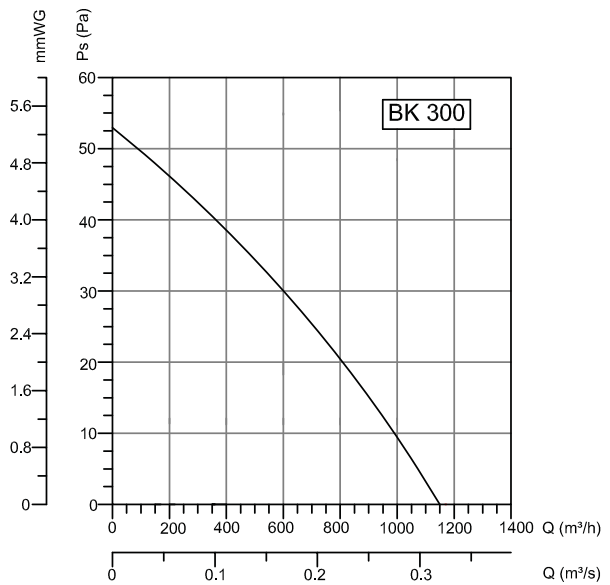
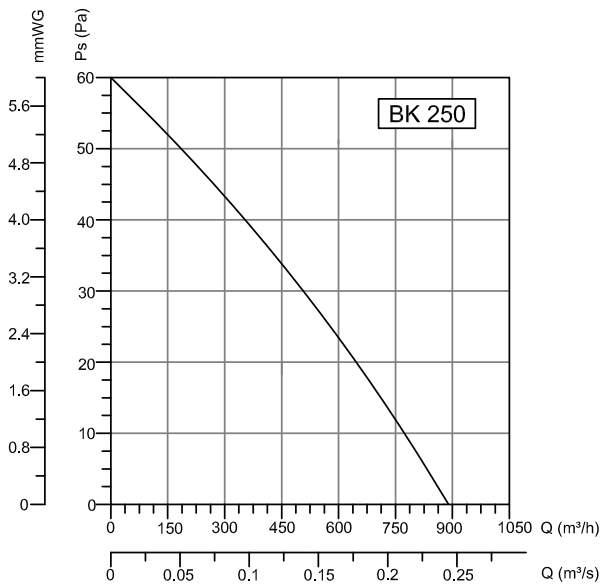
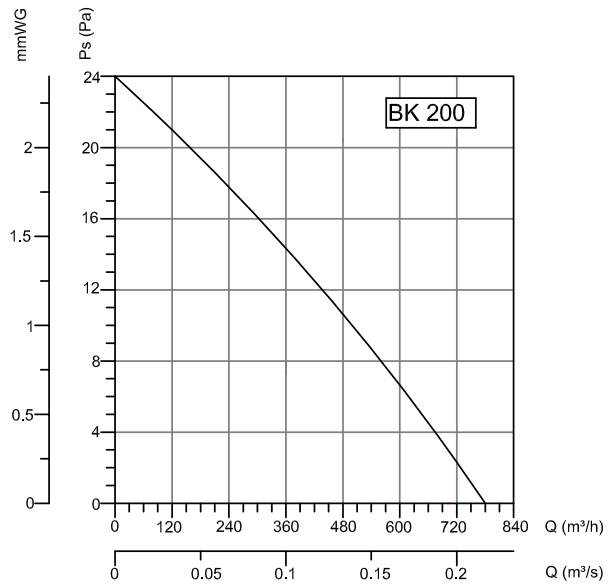
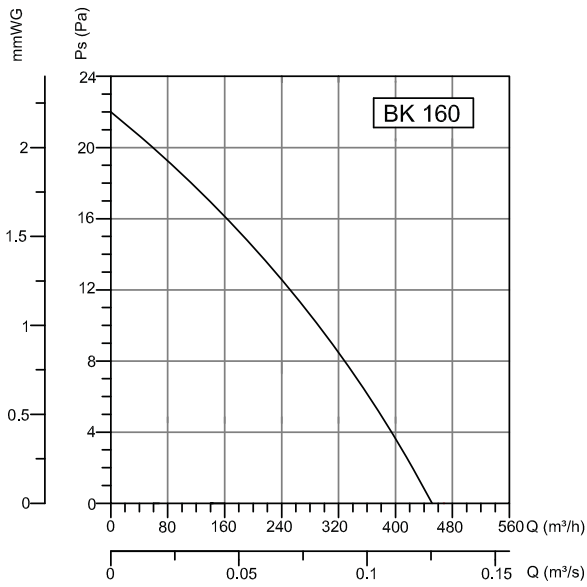

TYPE	VOLTAGE	FREQUENCY	POWER	CURRENT	SPEED	AIR FLOW	SOUND PRESSURE LEVEL	WEIGHT
	V	Hz	W	(A)	d/d	m³/h	dB(A)	kg
BB 160	230	50	25	0,16	1370	450	50	1,5
BB 200	230	50	30	0,2	1220	780	52	1,7
BB 250	230	50	55	0,4	1360	890	60	2,5
BB 300	230	50	70	0,5	1225	1150	65	2,8